



# Wiring Schematic Aftermarket Electric Fan Drive kit

EFD H345 US10 to GHG17

EFD with Bosch Alternator KIT # IS19900

EFD with Remy Alternator KIT #IS19910

Apply to all H3 model from B-1721 up to K-0185

Dec 2018

# Engine compartment component

Fan and shroud installation



Fan power BOX



# Rear junction box components

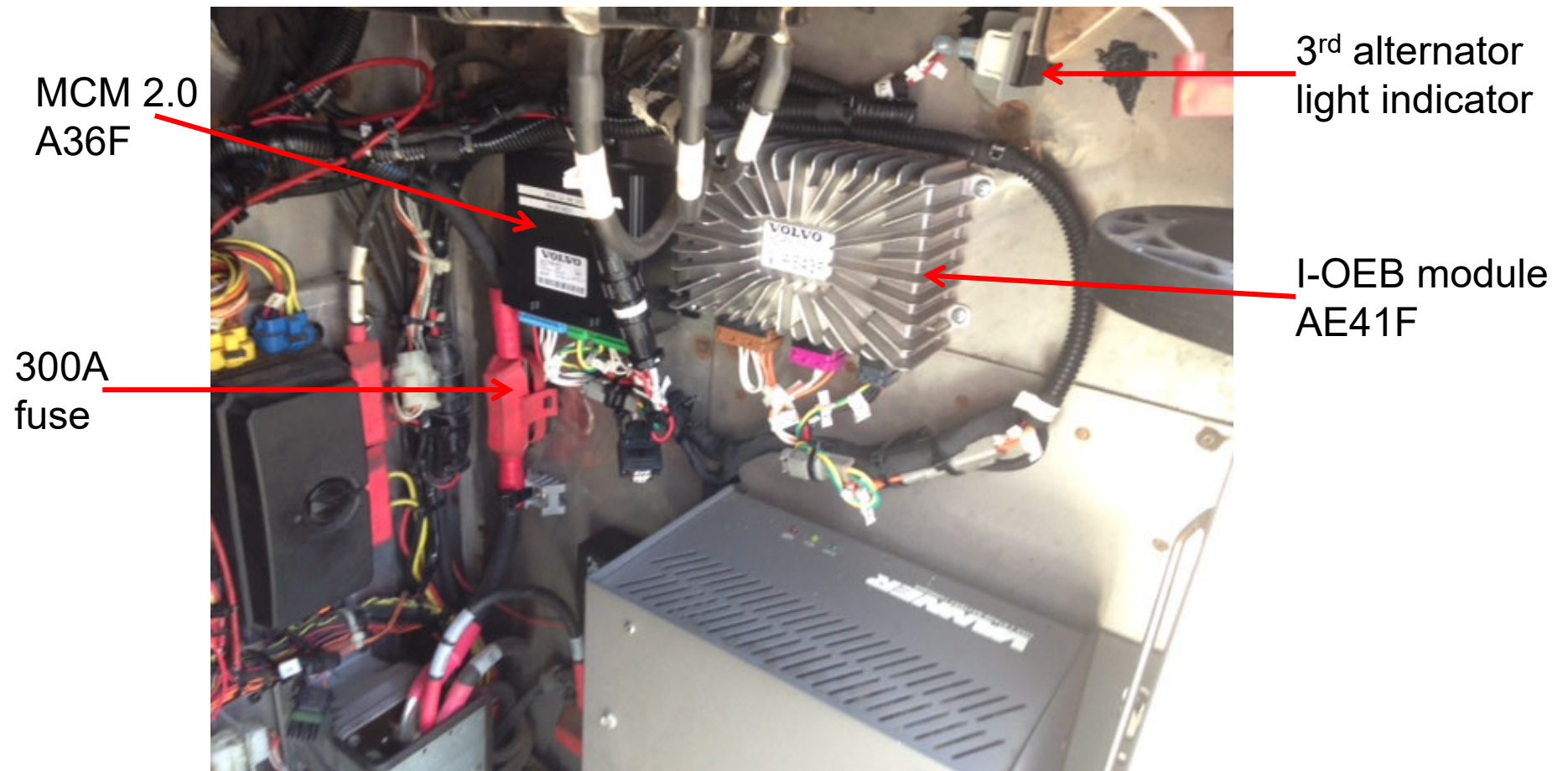

# WIRING HARNESS AND BATTERY CABLE

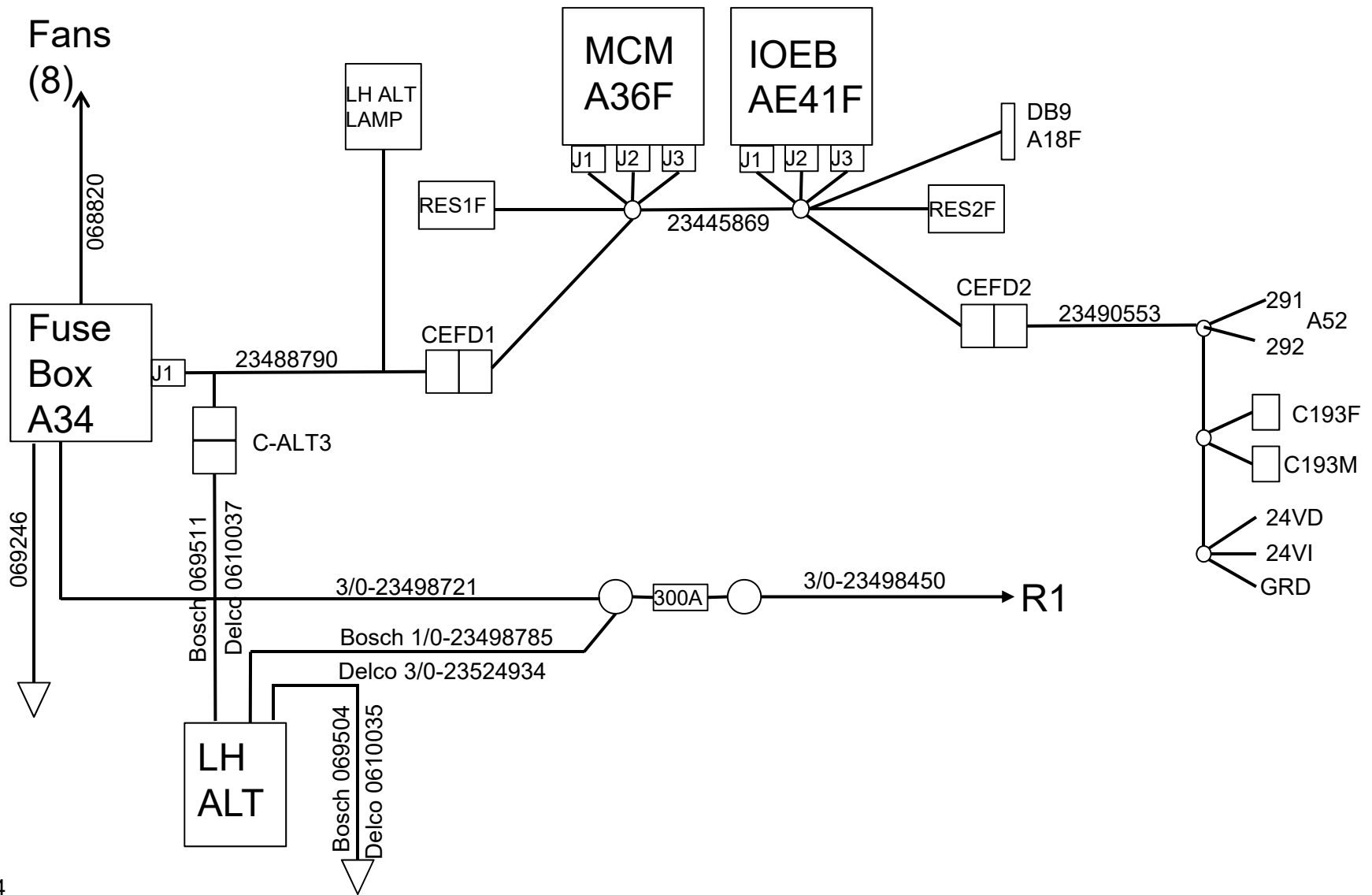

# WIRING DIAGRAM MCM

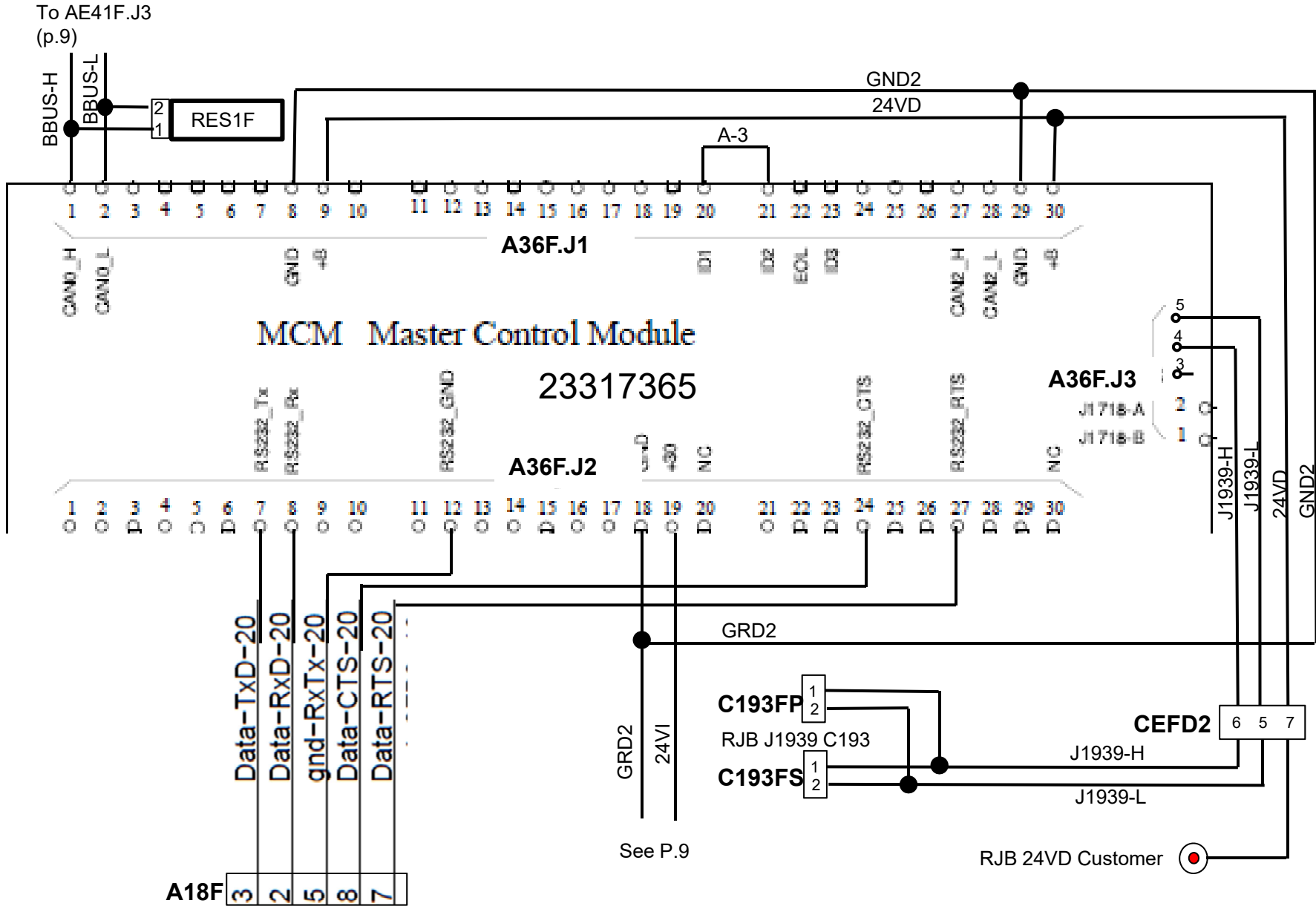

# WIRING DIAGRAM I-O module

IO-EB (22722850)

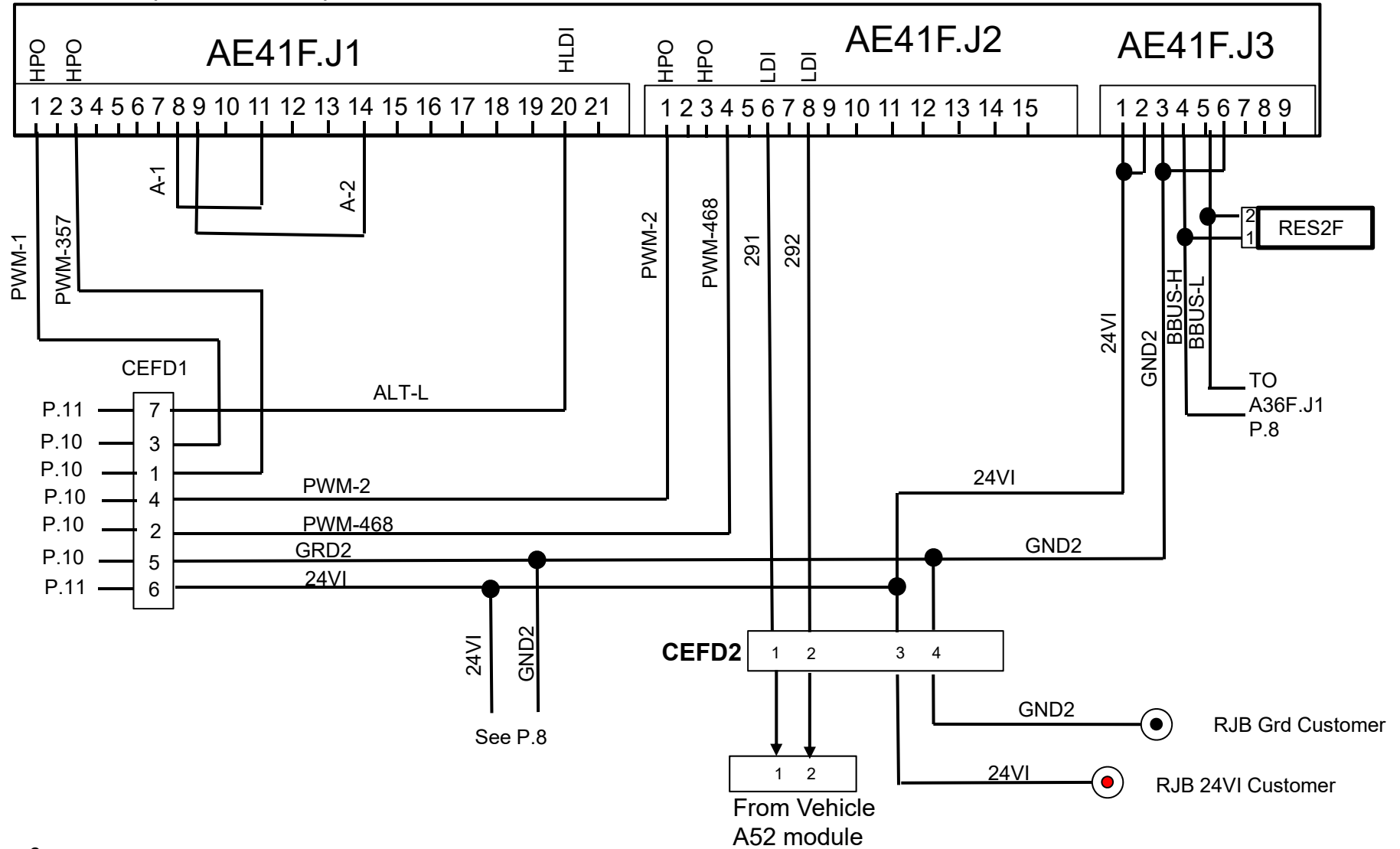



# WIRING DIAGRAM FAN

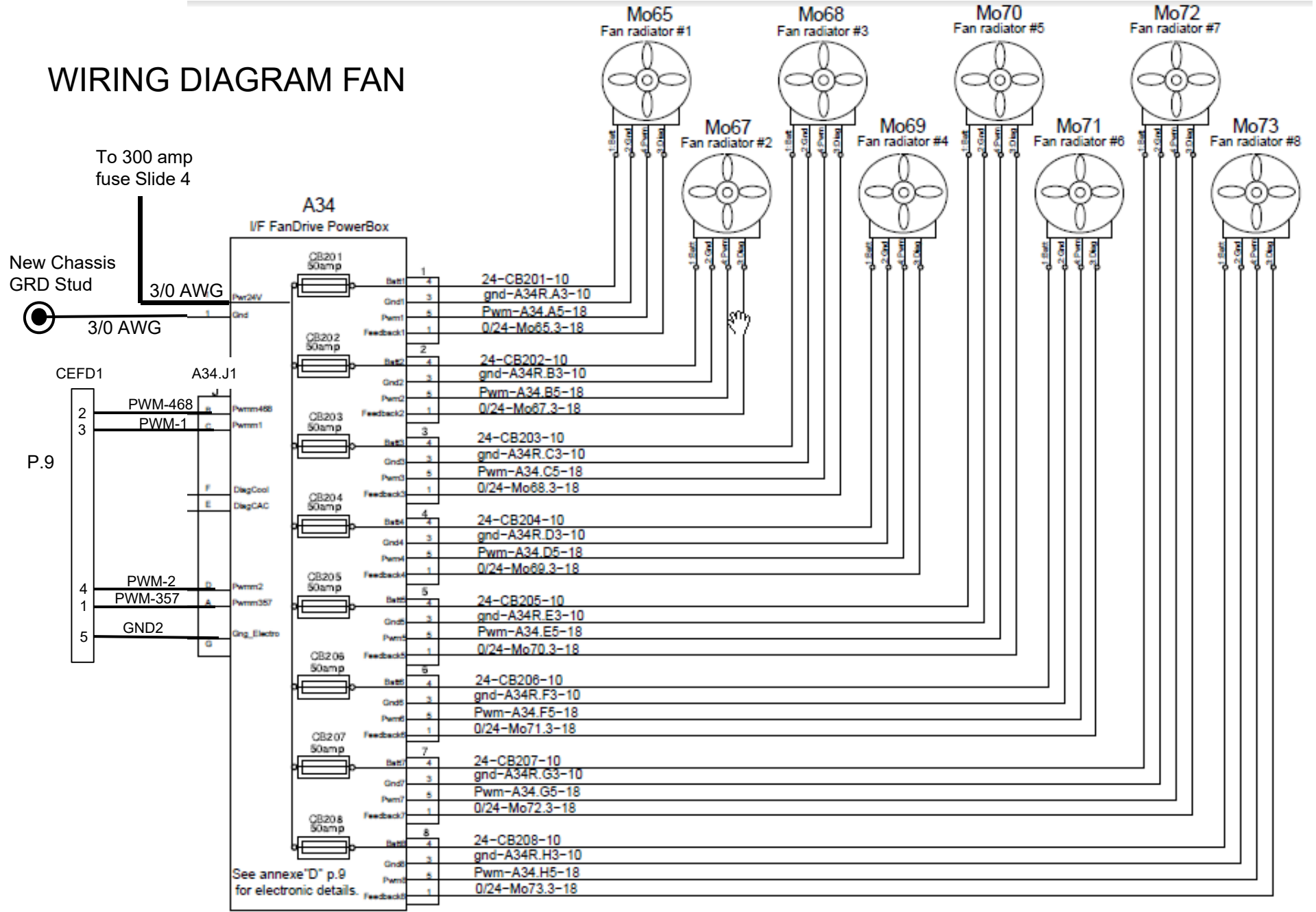

# 3<sup>RD</sup> BOSCH ALT WIRING DIAGRAM

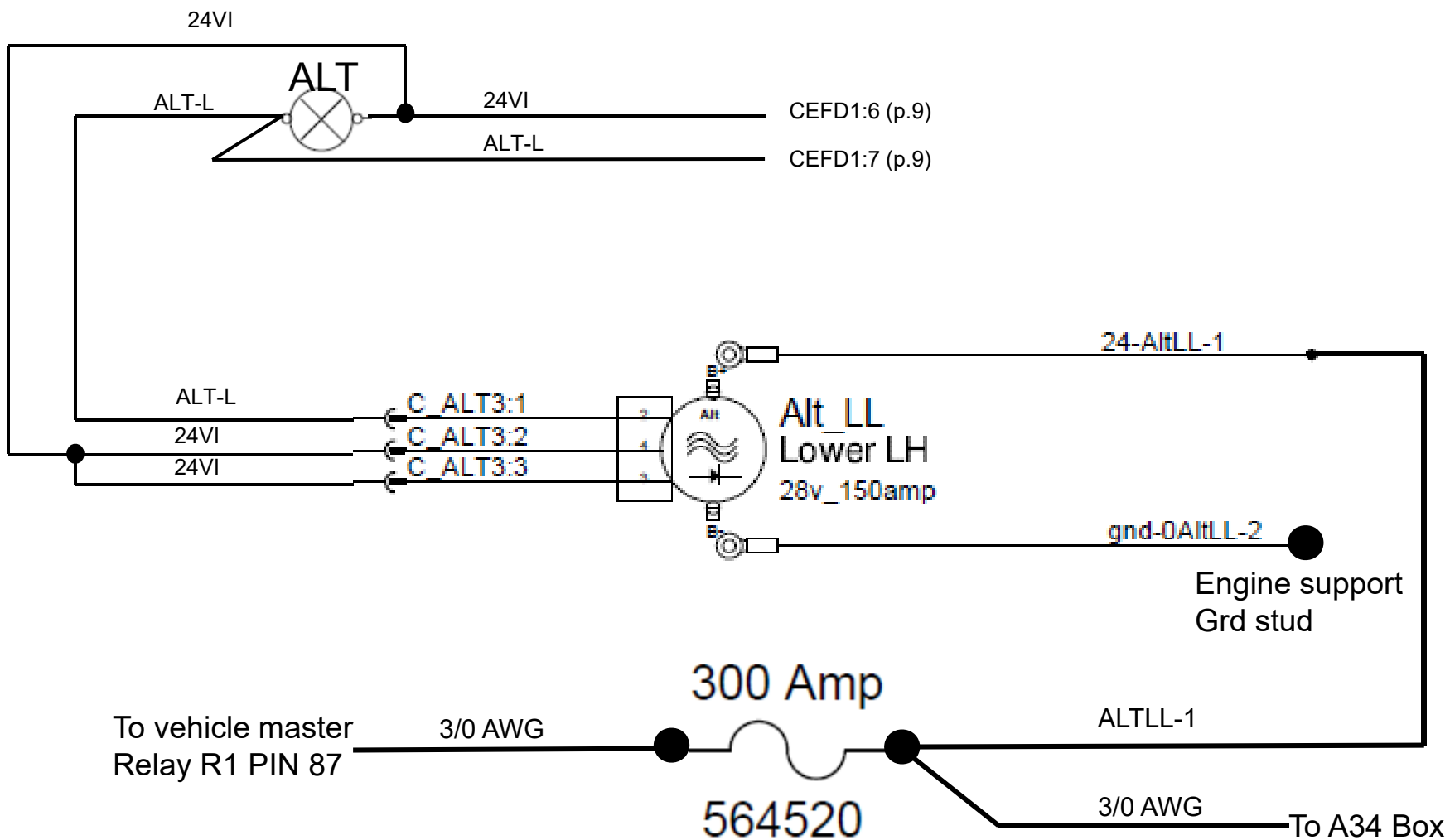



# 2<sup>ND</sup> REMY ALT WIRING DIAGRAM

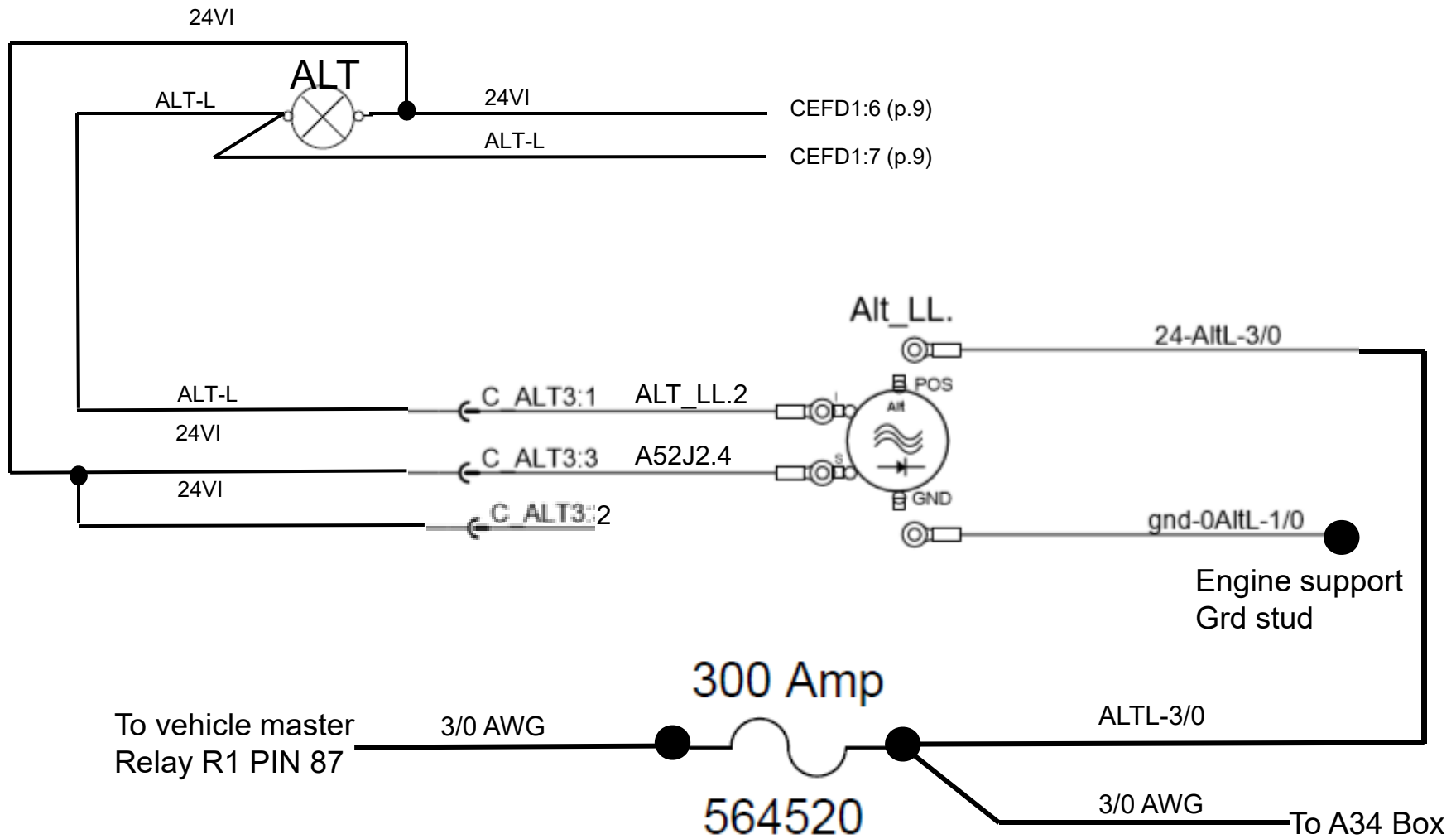

# H3VIP with driver's air only

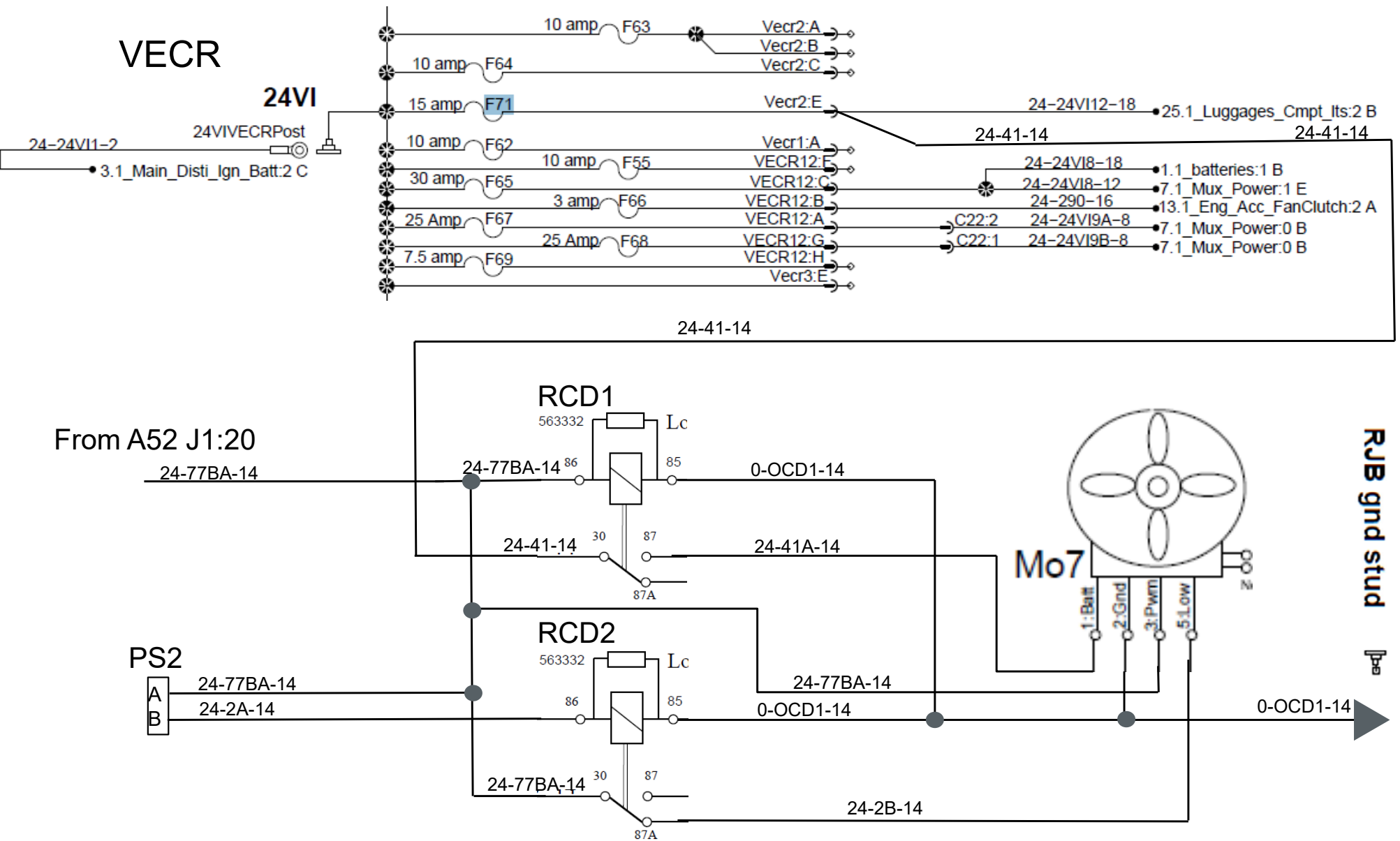



**THE ULTIMATE  
EXPERIENCE**

**PREVOST**